

FEATURES

- Capacities 50–500 kg
- Anodized aluminum construction
- OIML R60 approved
- IP67 protection
- For use in tension or compression
- 6 wire (sense) circuit

APPLICATIONS

- Hopper (Tank weighing)
- Hybrid scales
- Belt weighing
- Lever arm conversions
- Material testing machines
- Vibrations filling equipment
- Dynamometers

DESCRIPTION

Model 614 is a tension-compression load cell. Humidity resistant coating and shielded cables enable this load cell to be used in harsh environments while maintaining its operating specifications.

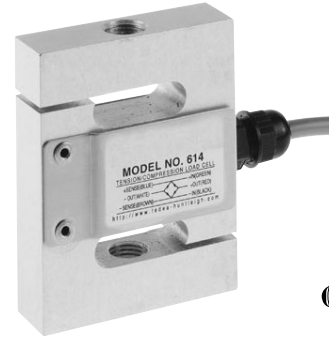

The additional sense wires compensate for changes in lead resistance due to temperature change and/or cable extension.

Ideally suited for lever conversions, hanging scales, force measurement and a wide range of other industrial applications.

Model 614 is made from aluminum.

OUTLINE DIMENSIONS in millimeters

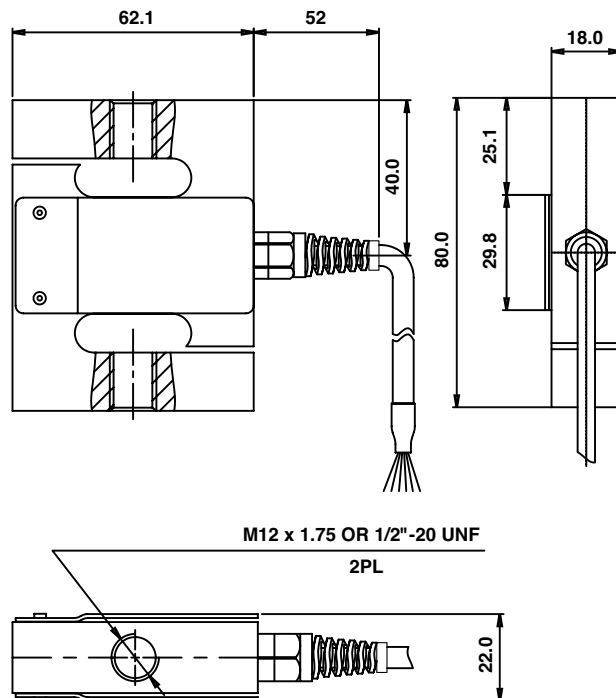

SPECIFICATIONS				
PARAMETER	VALUE			UNIT
Rated capacity—R.C. (E _{max})	50, 100, 150, 200, 300, 500			kg
Accuracy class	Non-Approved	C3*		
Maximum no. of intervals (n)	1000	3000		
Y = E _{max} /V _{min}	2500	8000	12000**	
Rated output—R.O.	2.0			mV/V
Rated output tolerance	0.2			±% mV/V
Zero balance	0.02			±% mV/V
Zero return, 30 min.	0.05	0.017		±% of applied load
Total error (per OIML R60)	0.05	0.020		±% of rated output
Temperature effect on zero	0.01	0.0023		±% of rated output/°C
Temperature effect on output	0.003	0.0012		±% of load/°C
Temperature range, compensated	-10 to +40			°C
Temperature range, safe	-30 to +70			°C
Maximum safe central overload	150			% of R.C.
Ultimate central overload	300			% of R.C.
Excitation, recommended	10			VDC or VAC RMS
Excitation, maximum	15			VDC or VAC RMS
Input impedance	415±15			Ω
Output impedance	350±3			Ω
Insulation resistance	>2000			MΩ
Cable length	3.0			m
Cable type	6-wire, braided PVC, dual floating screen			Standard
Construction	Plated (anodized) aluminum			
Environmental protection	IP67			

* 50% utilization

** Y=8000 for capacities 50–200 kg. Y=12000 for capacities 300–500 kg

All specifications are subject to change without notice.

Wiring Schematic Diagram (Balanced bridge configuration)

